



ARS72-M416.09 S31

Manual tool change

Item no. **10004022**

HF-Spindle for dressing of grinding wheels

Bearings

Hybrid ball bearing (pcs)	3
Lifetime lubricated	maintenance free

Motor

Motor technology	3-phase asynchronous drive (no brushes or sensors)
Frequency	533 Hz
Motor poles (pairs)	2
Rated rotation speed	16.000 rpm
Acceleration/braking value Per second	10 000 rpm (other values by consultation)

Power values

Liquid cooled

	Pmax./5s	S6-60%	S1-100%	
Rated power	3,4	2,6	2,2	[kW]
Torque	2,226	1,793	1,413	[Nm]
Voltage	367	367	361	[V]
Current	10	7,4	6,3	[A]

Power values

Compressed air cooled

	Pmax./5s	S6-60%	S1-100%	
Rated power	3,4	1,2	0,68	[kW]
Torque	2,57	0,95	0,61	[Nm]
Voltage	370	301	259	[V]
Current	11,5	5,2	3,8	[A]

ARS72-M416.09 S31

Manual tool change
Item no. **10004022**

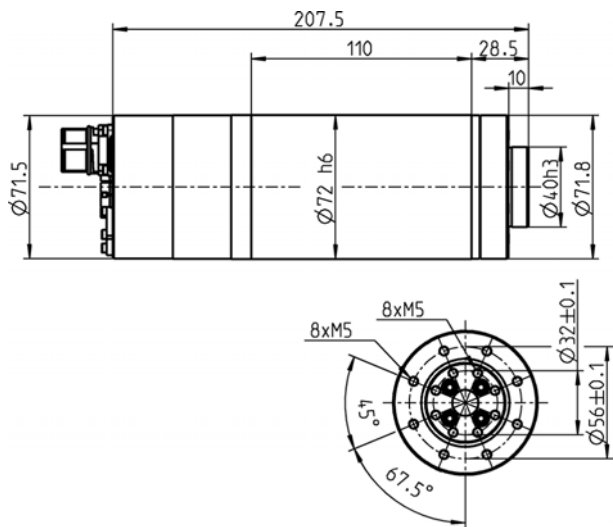

Dimensions

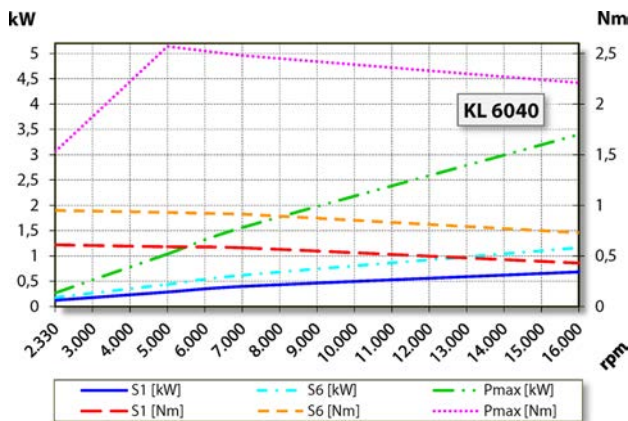

Performance Diagram

Compressed air cooled

Measurement of power is funded by in-house testing.

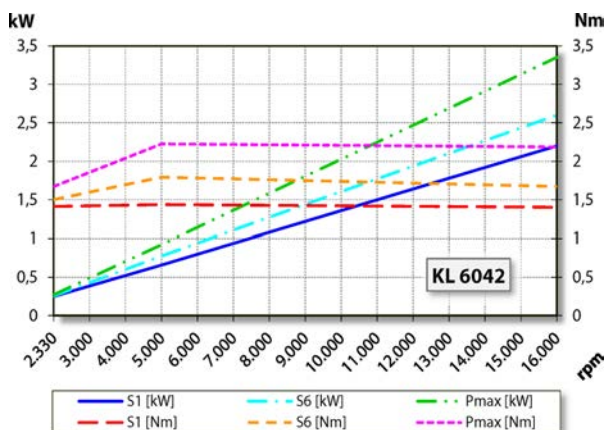

Performance Diagram

Liquid cooled

Measurement of power is funded by in-house testing.

Characteristics

Speed sensor	Differential magneto resistor (TTL) Number of signals = 6
Motor protection	PTC 130°C Pt1000
Housing	Stainless steel
Housing diameter	72 mm
Cooling	Compressed air cooled Liquid cooled
Heat dissipation	Via the spindle holder
Housing temperature	< + 45° C
Ambient temperature	+ 10°C ... + 45°C
Sealing air	
Protection category (sealing air turned on)	IP54
Tool change	Manual tool change

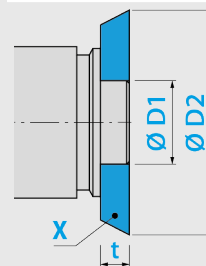

Tool Holder:
X = grinding wheel
D1 = 40 h3 mm
D2 = 100 mm
t = 10 - 20 mm

Clockwise and anticlockwise	
Coupler plug	9-pin (SpeedTEC)
Weight	~ 4,1 kg
Axial run-out of mounting surface	< 2 μ