



SP33-M260.01 S26

Manual tool change

Item no. **13502000**

HF-Spindle for high-speed milling, -grinding, -drilling, -engraving

Bearings

Steel ball bearing (pcs)	3
Lifetime lubricated	maintenance free

Motor

Motor technology	3-phase synchronous drive (no brushes or sensors)
Frequency	1.000 Hz
Motor poles (pairs)	1
Rated rotation speed	60.000 rpm
Acceleration/braking value Per second	10 000 rpm (other values by consultation)

Power values

Uncooled

	Pmax./5s	S6-60%	S1-100%	
Rated power	0,45	0,42	0,35	[kW]
Torque	0,102	0,088	0,075	[Nm]
Voltage	31	31	31	[V]
Current	16,1	13,4	10,8	[A]

SP33-M260.01 S26

Manual tool change
Item no. 13502000

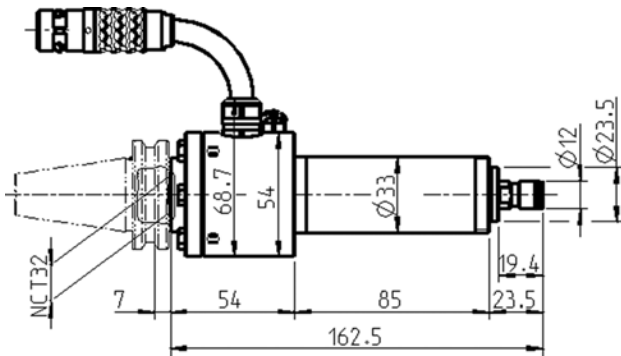

Dimensions

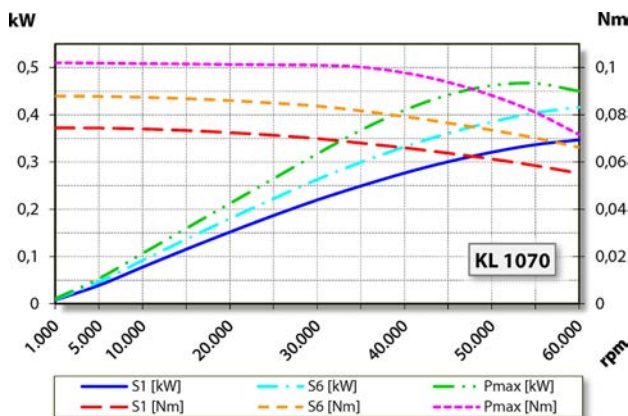

Performance Diagram

Uncooled

Measurement of power is funded by in-house testing.

Characteristics

Speed sensor	Differential magneto resistor (TTL) Number of signals = 6
Motor protection	PTC 100°C
Housing	Stainless steel
Housing diameter	33 mm
Mount	Adapter taper, NCT 32 Optional accessories (BT30/40/50, SK30/40/50, CAT40/50, HSK-A63, HSK-A100, PSC63/32/45)
Cooling	Uncooled
Heat dissipation	Via the mount
Housing temperature	< + 45° C
Ambient temperature	+ 10°C ... + 45°C
Sealing air	
Protection category (sealing air turned on)	IP54
Tool change	Manual tool change
Collet type	ER 8 Optional accessories
Clamping range up to	5 mm (13/64")
Clockwise	
Coupler plug	8-pin metal
Weight (without taper)	~ 1,4 kg
Inner taper run out	< 1 µ